

Advanced control in cogeneration utility management

by Sean Goodhart, Jun Nishizawa, Kunihisa Yano and Hiroyuki Yada

DMCplus advanced control technology has been successfully applied at more than 1000 plants worldwide. This article details a steam and electrical (cogeneration) power application at the Mitsubishi Chemical Corporation (Mitsubishi) Yokkaichi Plant in Japan. The objective of the DMCplus advanced control system is to drive the plant to the lowest operating cost for the steam and electrical power while meeting user demand at the site.

Dynamic matrix control (DMC), a form of model predictive control, was first introduced to handle complex multivariable plants with strong interactions and competing constraints¹ and is now widely used as an industrial control solution. Fig. 1 illustrates the generic DMCplusTM advanced control software structure.

Independent process 'handles' that are moved to control the plant are termed manipulated variables (MVs) and are typically loop set points or valve positions. Dependent process measurements to be maintained at set points (or within ranges) are controlled variables (CVs). Open-loop prediction of controlled variables is determined from a process model identified by engineers as a result of a plant test in which the different MVs are moved to record their effect on the process. A steady-state optimiser based on the economics of the process is solved at each controller iteration using the current state of independent manipulated variables and predicted value of dependent controlled variables at the future steady state. The optimisation problem is then solved based on the predicted steady state without the process having to reach that condition. Steady-state targets are determined with either quadratic or linear programming (linear in this application).

Steady-state targets from the linear program are executed by the controller. The linear program's solution and controller set points are always consistent because dynamic models programmed into the controller by the

project engineers provide the steady-state gains used by the linear program. The linear program thus reaches the optimum economic steady state for the system within limits specified for the manipulated and dependent controlled variables.

Mitsubishi is among the world's top ten chemical companies in terms of operating scale. Having invested in advanced control and rigorous non-linear real-time optimisation² on process units at multiple sites beginning in the early 1990s, the company is now extending its implementation to the utility systems serving these manufacturing plants.³ The Yokkaichi project began with a benefit evaluation by AspenTech in October 1996. Implementation began in early 1998 and the main advanced control system was completed in June 1999. Final completion followed in March 2000 with a special configuration for a specific shutdown mode.

Process control and optimisation objectives

The utility management system must meet the steam and electrical requirements of the chemical plant at minimum cost, subject to the operating constraints of the process and generation equipment. To achieve this, the new advanced control system provides a dynamic response to energy demand and redistributes steam flows amongst the boilers and the turbines. The control objectives are summarised below.

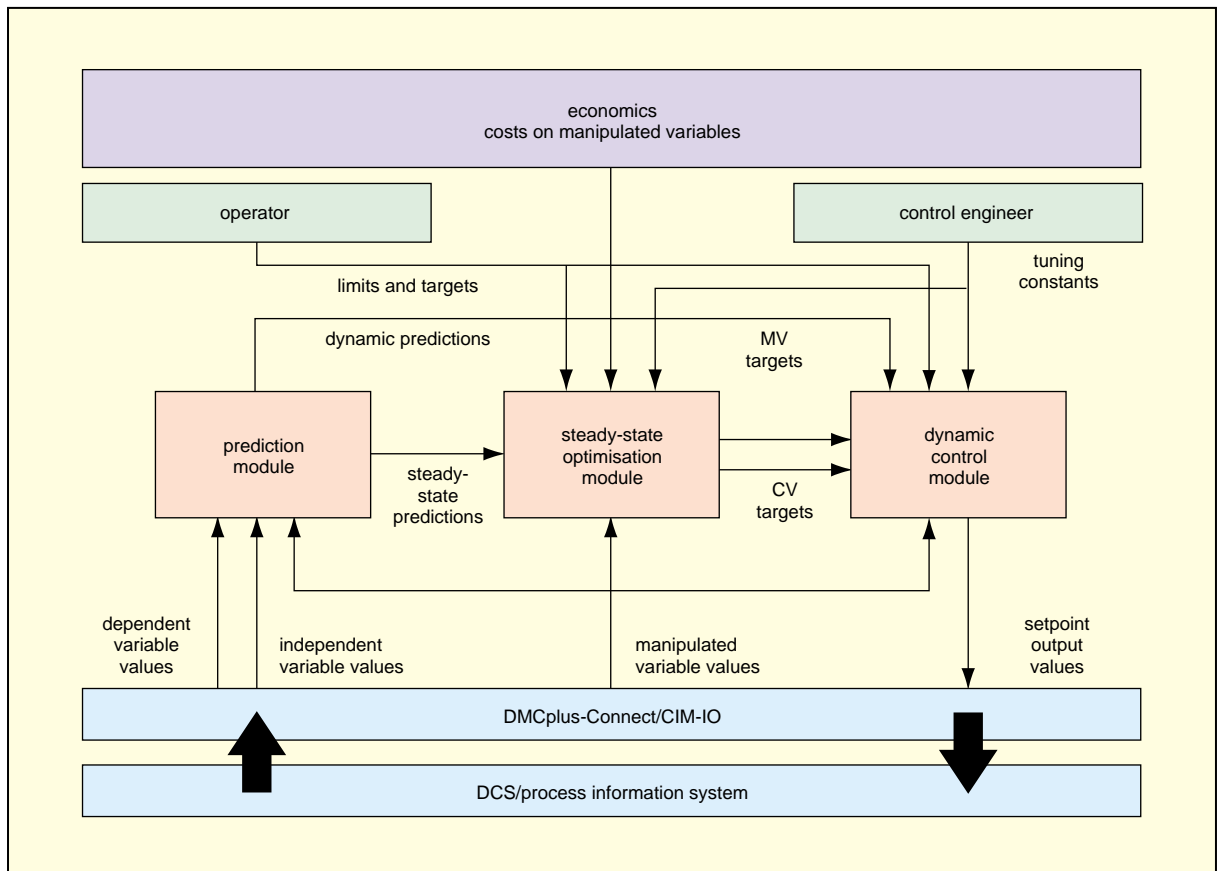

Fig. 1 DMCplus Control Structure

Header pressure control (HP, MP and LP steam)

When user demand changes, the control system must adjust the steam flow to the high-pressure (HP), medium-pressure (MP) and low-pressure (LP) headers. Any change in user demand changes the steam required for the super high-pressure steam header and thus changes the fuel input to the boilers. This function is provided by the regulatory distributed control system (DCS) pressure controls for all header pressures and allows rapid rejection of disturbances.

The new multivariable control system manipulates extraction pressure set points to alleviate steam system constraints. This strategy uses turbines and pressure reducing valves (PRVs) in a consistent, co-ordinated way, with the steady-state optimiser driving the header pressures to their minimum. It also minimises header pressure transients and maximises electricity generation by minimising the use of PRVs. The control system addresses several pressure upsets on different headers concurrently.

Boiler load allocation

Boiler load allocation must be dynamically controlled for rapid response to maintain header pressures and electrical power targets. The super high-pressure header is maintained by DCS level controls – one boiler

for each 120 kg/cm² header changes load to maintain pressure. As the advanced control system manipulates turbine extraction flows and PRVs, the DCS automatically changes the load of the ‘swing’ boiler. The relationship between turbine extraction flows, PRVs and the load is included in the controller model, and it can manipulate the handle with the lowest incremental cost.

Incremental cost is a function of fuel cost and boiler efficiency. The highest efficiency boiler with the cheapest swing fuel increases steam flow the most during an increase in steam demand. During a steam demand decrease, the boiler with the highest incremental cost decreases the most. If the swing boiler is constrained on load, fuel delivery (oil pressure or coal mill throughput) or de-NO_x temperature, other available boilers can be increased or decreased to put the swing boiler back into control range. This type of constraint handling is a standard feature of the DMCplus software. Mitsubishi’s power plant system limits control outputs to constrained boilers and reallocates steam demand to unconstrained boilers. For example, if it becomes necessary to alleviate constraints, interconnection flows between steam headers of the two power stations (denoted 1PS and 2PS) can be changed to reallocate the load, as indicated in Fig. 2.

Turbine load allocation

The advanced control system allocates steam among the turbines and PRVs to minimise the net cost of electricity for incremental changes in process steam demand. The controller redistributes the HP, MP and LP steam between the turbines and PRVs for minimum cost, defined as the cost to produce process steam minus a credit for the electrical power generated. This is also a standard feature of the DMCplus technology.

Turbine and header pressure controls must immediately respond to changes in steam header pressure at any level. This is accommodated by the DCS-level control, which provides the fastest dynamic response of the turbine pressure controls and header pressure regulatory controls. Additionally, to satisfy the demand change, the multivariable control system will reallocate steam distribution to the turbines to minimise PRV flows (the controller is run every 20 seconds for this application). The steady-state optimiser determines steam and electrical power load targets for each turbine. This provides minimum cost load distribution while respecting system and equipment constraints.

Tie line control

The multivariable controller now controls the amount of purchased electricity from the local power company. The Mitsubishi plant has self-generated resources, and the steady-state optimiser can maximise on-site electrical generation when it is cheaper than the power company price. As the price changes, the controller can 'back down'

on-site generation and rely on the power company when the price is less than the cost of self-generation.

The primary objective of tie line control is to control the total energy purchased based on a standard rate schedule. The standard rate schedule for electricity from the power company changes prices several times per day and varies with days of the week, holidays and season changes; an electricity calendar application determines the current price from look-up tables. The steady-state optimiser/linear program cost factors are then automatically retrieved from the power plant database (AspenTech's InfoPlus-X™). As the costs per kWh rise and fall, the steady-state optimiser modifies the optimum utility plant operating conditions. For example, when the power company electricity price is high, the steady-state optimiser may indicate a benefit from exhausting LP steam to the atmosphere, and the advanced control system will open the vents.

Process overview

The Yokkaichi site was once two separate companies and consequently has two power stations denoted '1PS' and '2PS', with a total capacity of 720 tonne/hour steam and over 100 MW of on-site generating equipment. The distribution and names of the equipment are illustrated in Table 1. The stations each have two boilers producing 120 kg/cm² superheated super high pressure (SP) steam, which is let down through back pressure turbines. Multiple extraction points provide steam to high-pressure (HP), medium-pressure (MP) and low-

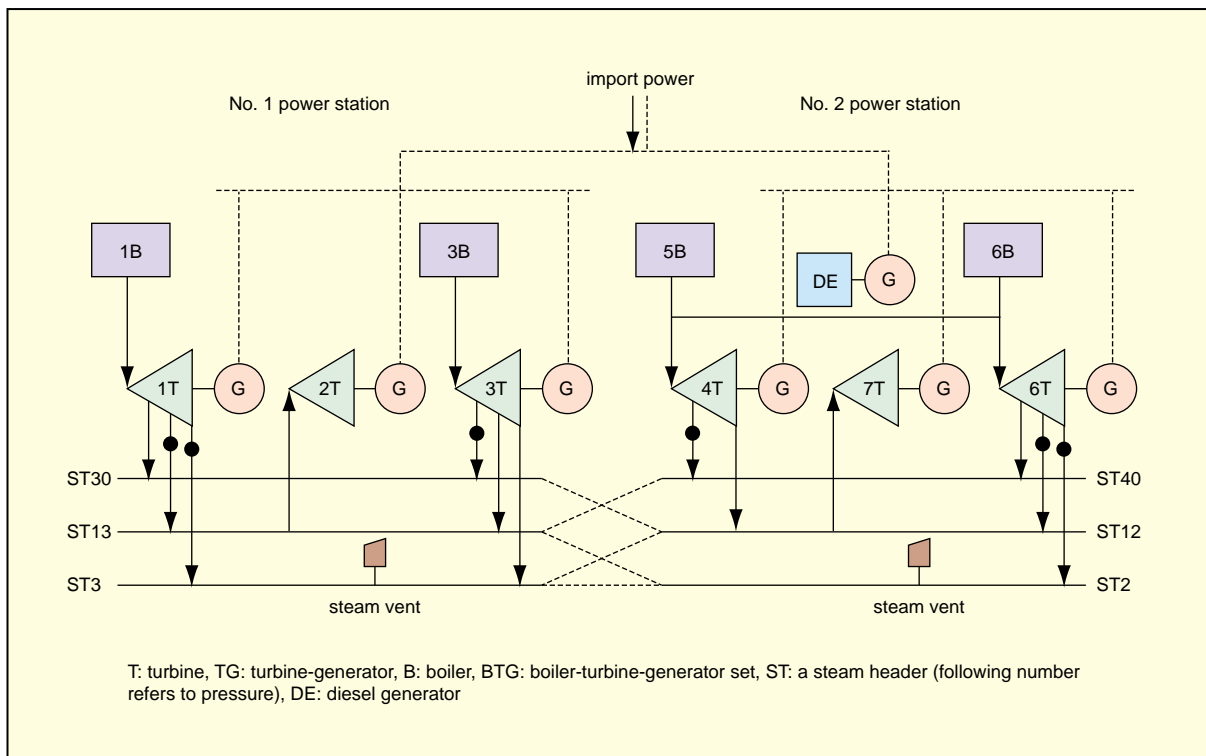

Fig. 2 Simplified schematic of the Yokkaichi power plant

Table 1 Yokkaichi steam and utility plant

1PS		2PS	
1B (190 T/h boiler)	1TG (back pressure turbine, 23.5 MW generator)	5B (100 T/h boiler)	4TG (back pressure turbine, 8.35 MW generator)
3B (150 T/h boiler)	3TG (back pressure turbine, 22.5 MW generator)	6B (280 T/h boiler)	6TG (back pressure turbine, 41.8 MW generator)
	2TG (condensing turbine, 10.49 MW generator)	DE (6.16 MW diesel generator)	7TG (condensing turbine, 9.5 MW generator)
individual 120 kg/cm ² headers from boilers	ST30 (30 kg/cm ²), ST13 (13 kg/cm ²) and ST3 (3 kg/cm ²) pressure headers	connected 120 kg/cm ² headers from boilers (also connected to ethylene plant steam system)	ST40 (40 kg/cm ²), ST12 (12 kg/cm ²) and ST2 (2 kg/cm ²) pressure headers

pressure (LP) headers for consumption by site users and a condensing turbine. Fig. 2 is a simplified utility plant schematic.

Prior to this project, the HP, MP and LP headers were not normally connected between 1PS and 2PS. They were occasionally connected via pressure-reducing valves (PRVs) during shutdown periods to meet steam demands throughout the plant when boilers/turbines were being maintained. These interconnections are utilised in the controller, providing more operational flexibility.

At both power stations the conventional DCS relies on one boiler providing base load with a second in swing mode, with one set of turbine extraction flows to meet user demand flows while the second turbine extraction (or inlet) flows are modulated to control pressure.

Electricity distribution

Power station generators run in parallel with the electricity company supply grid. During grid failures, the Mitsubishi utility plant is disconnected and turbines are frequency (speed) controlled; this operation is not in the scope of the controller. The electricity company supply grid provides import electric power when Mitsubishi's generators do not meet user demand or on-site generation is more expensive than imported power.

The imported electricity contract has six periods based on an electricity calendar. The daytime site electrical load is high and the load at night is low. The export of electricity to the grid is not allowed, so the import power low limit is zero. The power contract has an upper bound on purchased power in any one tariff.

A number of links in the site electricity grid with maximum power ratings represent additional constraints that the controller must respect when changing boiler or turbine loads to meet steam and electricity demands.

Yokkaichi power plant project

AspenTech's standard implementation methodology (see Reference 4) was followed for this project. The project methodology is as important to overall success of the application as the technology, as the software tools are

used to develop a customised control system specific to the needs and configuration of the particular plant or unit. The specific steps and their importance for the utility plant project are described below.

Project kick-off and preliminary testing

The preliminary controller design developed during the benefit assessment was reviewed in this phase. The scope encompassed a single controller for the boilers, turbines, generators and pressure reducing valves and vents, with the objective of achieving a minimum cost of operation. Individual controllers were also planned for the boilers, to improve local control of boiler superheat temperature and NO_x emissions.

The power plant operation was also reviewed during the preliminary testing to determine any necessary changes for the existing base level control and instrumentation. Some of DCS systems for the power utility plants required an upgrade, and a new DCS was installed for panel-mounted equipment. It was necessary to complete these changes and regulatory tuning before the more rigorous response testing and subsequent modelling began.

Response testing

The model form used in DMCplus is a step response, identified from actual process data obtained during a standard response test. Each of the control handles, or manipulated variables, was moved during the test and the subsequent responses in the utility plant's controlled and constraint variables were measured.

AspenTech and Mitsubishi control engineers, working closely with board operators, conducted response testing on a 24-hour basis. The testing was done for the normal utility plant configuration, then repeated for each of the DCS base scheme configurations at each of the planned shutdown modes. The advanced control system design accommodates changes in DCS base-level control configuration that occur during any one of four different planned shutdowns, thus there are five possible configurations for the controller. The re-tests at the shutdowns were much shorter than the main test,

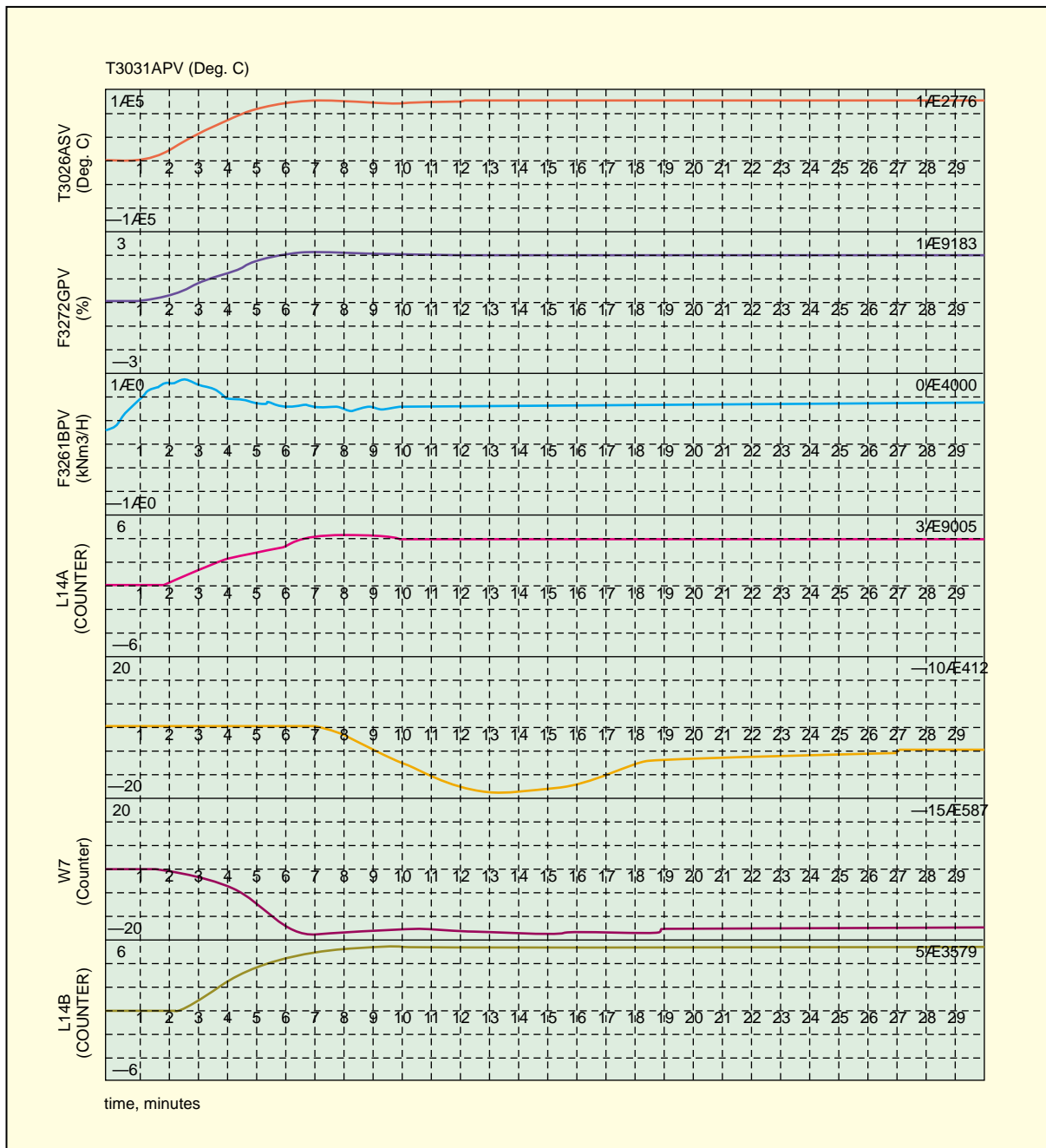

Fig. 3 Section of the 3B boiler dynamic matrix model

because they covered only the additional manipulated variables and identification of the new constraints. Shutdown mode models were assembled using many of the same step response curves as the normal operating mode model.

Model identification

Dynamic models of the plant produced during the response testing were then refined. The modelling tool, DMCplus Model, allows development of model identification cases, identification runs and validity checking.

The plant steady-state steam balance was used to validate the identified models.

The main controller under normal operation, 'M0', uses boiler load, generator power, extraction pressure and various calculated flows as manipulated variables. Pressure-compensated linearisations are performed within the DCS to convert valve openings into a tonne/hour flow signal. Constraint variables include import power, steam flows, extraction valve positions, header pressures and fuel flow and pressures. The feedforward variables include user steam flows,

Table 2 Controller sizes

controller	3B	6B	M0	M1	M3	M5	M6
number of MVs	1	3	20	16	17	17	13
number of CVs	1	6	37	35	34	32	30
number of FFs	10	1	9	7	8	7	8

byproduct fuel flows to boilers and steam temperature from each boiler.

Table 2 summarises the size of each controller in terms of the number of manipulated, controlled and feed-forward variables (FFs). Two boilers have advanced control: ‘3B’ and ‘6B’. The main controller is M0; M1, M3, M5 and M6 correspond to the different shutdown modes.

A small controller was developed for the coal-fired boiler, 3B. With only one MV and one CV, it provides improved superheat temperature control. The dynamic matrix model in Fig. 3 shows the effect on superheat steam temperature (T3031APV) of the desuperheater temperature (T3026ASV), combustion ratio (F3272GPV), a byproduct fuel (F3261BPV) and some soot-blowing events (L14A, L13A, W7, L14B).

Linear program cost development

The steady-state optimiser makes ‘sensible decisions’ about boiler and turbine loading, header pressure control and tie-line control. Unlike many commercially available utility management schemes, which often rely on heuristic rule-based approaches, the steady-state optimiser is a mathematical solution, and thus the controller handles all utility plant optimisation requirements in one step. The factors influencing the calculated linear program cost factors (calculated for each MV) are the fuel and import power prices, illustrated in Table 3.

Linear program cost factors ϕ_{MV_i} , in units of k¥ per hour, are calculated for each MV affecting the boiler loads and import power using:

$$\begin{aligned} \phi_{MV_i} = & -\Delta power_{import} \times Cost_{powerimport} \\ & + \Delta fuel_{1B} \times Cost_{fuel_{1B}} + \Delta fuel_{3B} \times Cost_{fuel_{3B}} \\ & + \Delta fuel_{5B} \times Cost_{fuel_{5B}} + \Delta fuel_{6B} \times Cost_{fuel_{6B}} \\ & + \Delta fuel_{DE} \times Cost_{fuel_{DE}} \end{aligned}$$

where $\Delta fuel$ and $\Delta power$ denote the steady-state change in fuel and imported power for a steady-state change in

Table 3 Factors affecting the utility plant organisation

cost influence	units
1B fuel oil price	k¥/kl
5B fuel oil price	k¥/kl
DE generator fuel oil	k¥/kl
3B coal price	k¥/T
6B fuel oil price	k¥/T
import power price	k¥/MWh

the related MV_i and $Cost$ denotes the per unit price for each fuel and unit of power. The gains used to calculate $\Delta fuel$ for a unit change in an MV are based on the Yokkaichi power plant steady-state steam balance model—the same model that was used to validate the identified model gains. Thus ϕ_{MV_i} provides the incremental cost change for each MV. The linear program then minimises the cost function $\Phi = \sum_i \phi_{MV_i}$, ensuring appropriate selection of MVs to move to alleviate constraints in the least expensive way. The calculation of the ϕ_{MV_i} has been implemented within the InfoPlus-X database using structured query language (SQL) calculations. An electricity calendar program determines the current import power price based on day of the year and time of day. Each time the power price changes, or the cost of a fuel changes then the ϕ_{MV_i} are automatically recalculated. The control system reads the ϕ_{MV_i} at each controller execution and the linear program determines new optimum operating points. This provides the tie line control, ensuring that the plant only imports power when the electricity company power price is less than that of self-generation.

Controller configuration, simulation and tuning

The basic configuration and tuning parameters were determined offline to ensure stable control when the actual controller was implemented online. DMCplus Build uses the identified model to configure the connection of independent and dependent variables in the controller to the DCS. It also configures on/off points, watchdog points and sub-controllers. An important feature in the control software groups related independent and dependent variables into sub-controllers, providing operators a single switch for a large block of the controller. A CV may belong to one or more sub-controller, but each MV only belongs to one sub-controller. If a sub-controller is turned off or a critical MV within a sub-controller is taken out of service, all related MVs are automatically taken out of the controller. The controller structure remains the same, with the sub-controller CVs being in prediction mode, rather than explicitly controlled.

This feature was very useful for the utility management advanced control. The main controller was divided into four sub-controllers depending on equipment and function, rendering the system easier for plant operators to use. The sub-controllers for each power station are termed ‘1PS’ and ‘2PS’, for the interconnecting headers between the stations ‘INT’ and the diesel generator ‘DE’. The import power is a CV appearing in all sub-controllers. Therefore, should sub-controller 1PS be turned off, the MV handles in sub-controller 2PS will be the main ones used to achieve the import power target. If sub-controller DE is also on, the diesel generator can be manipulated to achieve the import power target. Likewise, if sub-controller INT is on, the interconnecting flows can be changed to achieve the desired import power

or to alleviate other constraints at either power station. Many CVs in sub-controller 1PS and sub-controller 2PS appear in sub-controller INT. Without the sub-controller INT active, the only common CV in sub-controllers 1PS and 2PS is the import power.

After this basic configuration, controller tuning began. The controller configuration file (CCF) prepared with DMCplus Build was transferred to DMCplus Simulate, and studies were run to determine an acceptable initial tuning set. This initial controller tuning from the simulator was then saved back into the CCF, and the CCF and identified model were copied onto the control application server, a DEC Alpha server running OpenVMS.

Utility management system software

The software components of the utility management system comprise AspenTech's InfoPlus-X real-time database, the SQL calculation engine, DMCplus Online, CIM-IO interface to the DCS and GCS (graphics console system). The electricity calendar is a custom application using look-up tables to determine the import power price and maximum contracted purchase from the power company. The CIM-IO interfaces the InfoPlus-X database to four Yokogawa Centum DCS systems. DMCplus is interfaced directly to InfoPlus-X. Fig. 4 gives an overview of the utility management system.

The man-machine interface to the utility management system is provided by GCS, an open system for developing and using operator graphics and trends. The standard DMCplus View screens are hosted on the GCS system; additional functionality has been implemented and a set of operator screens was developed in Japanese. The custom screens include access for engineers to update fuel prices or inspect the status of the electricity calendar and linear program cost factors.

Controller commissioning

Following offline simulation, the next step was loading the controller configuration file (CCF) and model onto the

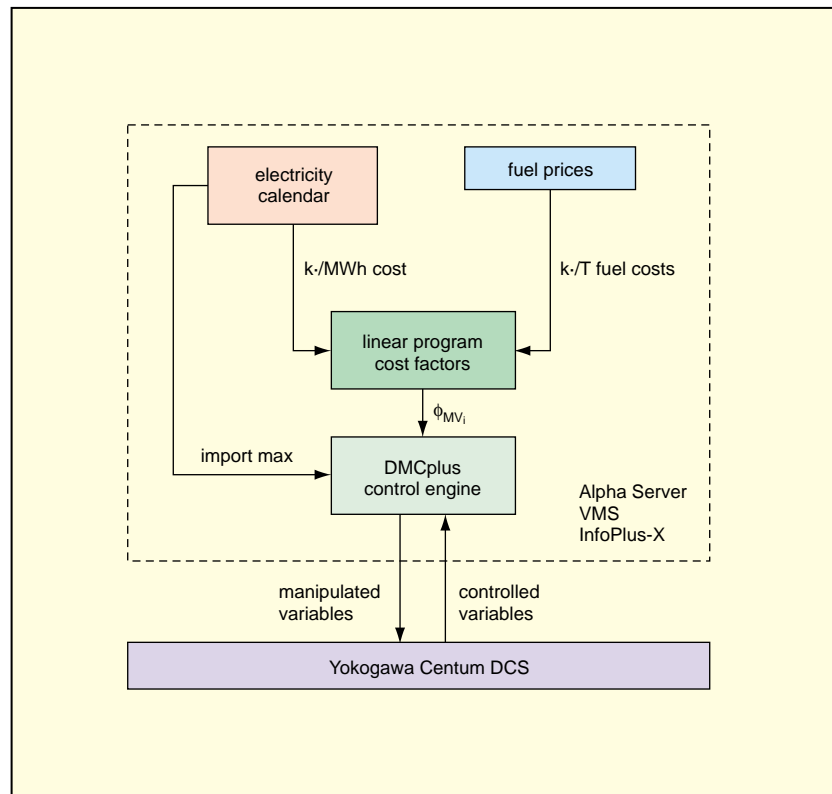

Fig. 4 Schematic of utility management system

The customer screens include access for engineers to update prices or inspect the status of the electricity calendar

Alpha. The controller was then started, with the ability to write set points down to the DCS disabled. This step allowed detailed inspection of the identified models. The prediction-error statistics automatically generated from the controller were trended to ensure that average model errors tended to zero. With the controller running in 'prediction mode', linear program targets were checked for a range of situations using the actual plant status as the starting point.

The ability to write set points is enabled for controller commissioning only when model prediction errors, expected move sizes and move directions are satisfactory. Fig. 5 illustrates the moment controller 3B was turned on with its initial tuning. Although a simple application, its effectiveness is clear. The control improvement derives from the model predictive control functionality of the system. Since the model captured the effect of a soot-blowing disturbance, the controller 'knows' to move the desuperheater spray to minimise the consequences of the disturbance. The performance of 3B was further improved by fine-tuning the controller during commissioning. Tuning changes were made as needed for each controller during this phase and operators were trained in use of the system during 24-

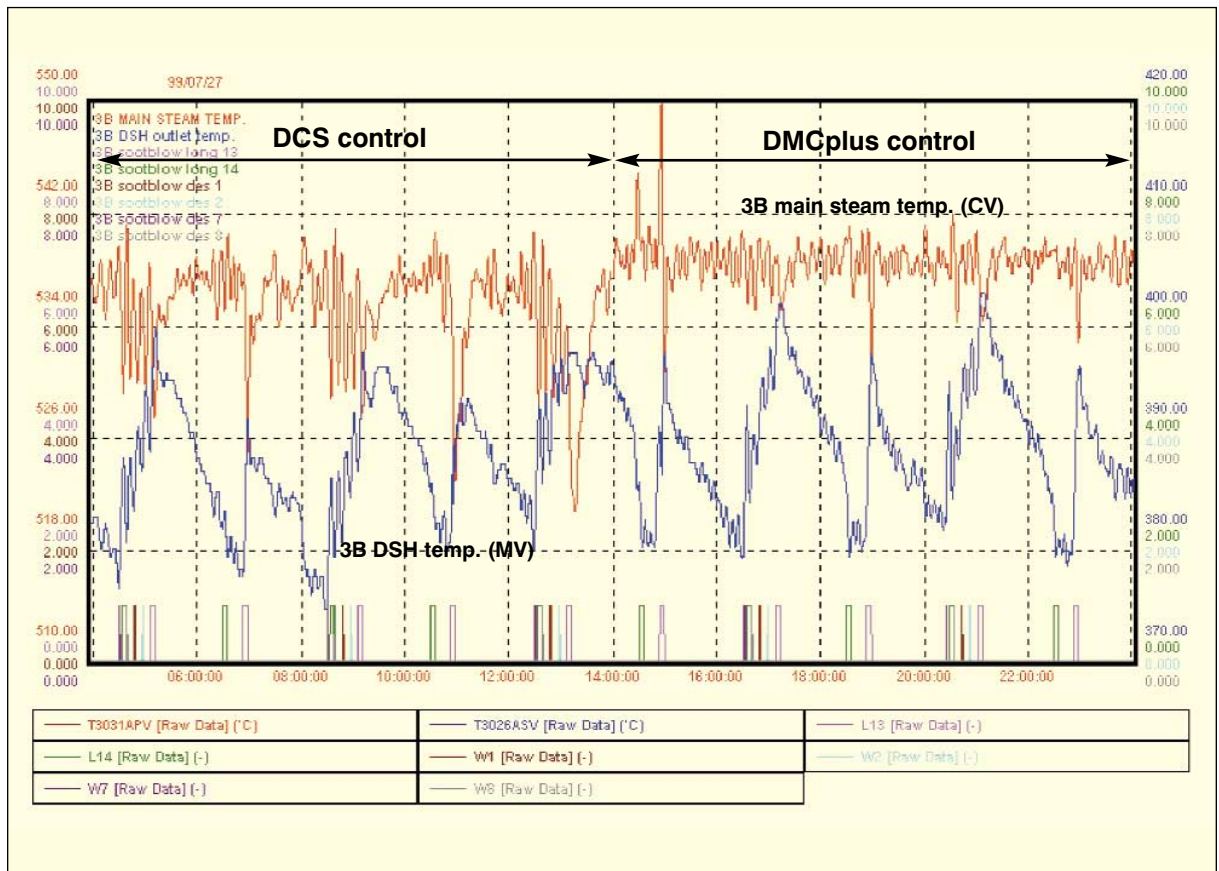

Fig. 5 Boiler control performance on turn-on of the controller

hour per day staffing by AspenTech and Mitsubishi engineers.

Ensuring that the controller model matched the site steam balance helped to ensure consistent operation, but there were still surprises. The controller used the steam interconnection rather than the handles usually used by the operators to alleviate certain constraints. The normal operating configuration did not usually use these interconnections because of the inherent difficulties of coordinating the two different sets of board operators. Thus, the controller created and exploited advantages in marginal costs that were previously unavailable.

Next, the electricity calendar and automatic calculation of linear program cost factors were enabled, resulting in additional enhancements in performance. With tariff changes, the controller may change costs on the MVs fairly dramatically. For example, low-pressure vents are minimised when import power is less expensive, but maximised when it becomes expensive. When it is cost effective the controller actually vents steam in order to make more electricity on-site. The automatic load-changing is illustrated in Fig. 6, covering 24 hours in August 1999.

Controller experience and benefits

The improvement in steam temperature control for the

coal-fired boiler 3B was impressive, giving clear benefit in that the target temperature could be raised. The additional temperature equates to increased power generation from 3TG.

The steam temperature controller for the oil-fired boiler 6B initially performed only marginally better than the conventional DCS PID scheme. Its benefit was clear in terms of disturbance rejection, with quick rejections of load change disturbances on temperature, but the improvement was not sufficient to allow an increase in target temperature. A significant problem was that the desuperheater spray loop, an MV, was not performing well with the many set point adjustments being made by the advanced control system. A simple redesign of the controller to use the desuperheater loop output rather than a set point allowed better performance. This illustrates the importance of choosing the correct base level in achieving overall success.

The 6B controller also encompasses NO_x emissions, manipulating ammonia flow to the de-NO_x unit and an air-air damper providing exhaust gas recirculation inside the boiler's furnace section. It provides improvement over the DCS-based scheme as load change disturbances are quickly rejected and the controller handles conflicting constraints to control both outlet NO_x and outlet/inlet NO_x ratio at the de-NO_x unit.

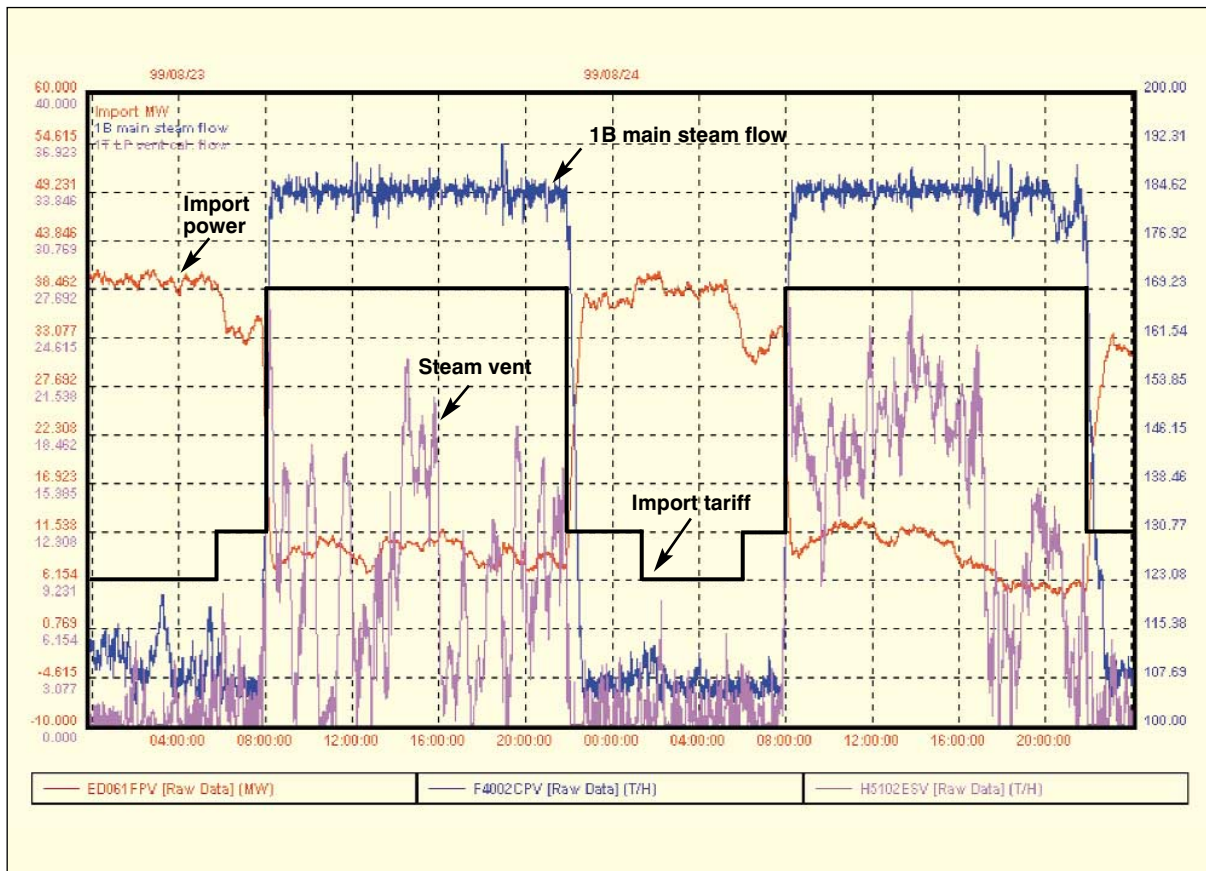

Fig. 6 Effect of power price changes on load allocation

The power plant application requires rapid sampling for rejection of the many disturbances. The 20s interval is close to the limit of reliable communication with the DCS. An issue that arose was pressure control of the 1PS user headers. They supply many batch production plants, and disturbances are frequent. The project included multi-variable pressure controls for 1PS as well as a conventional cascade arrangement in the DCS. There is little to distinguish performance between these systems. DCS control occasionally oscillates with large disturbance, whereas the controller's pressure control may be slower to begin responding to a disturbance (20s can be a long time) but does not cause oscillation. There were no problems with pressure controls at 2PS, where load disturbances are less severe.

The main controller provides all of the desirable features of a utility management system:

- minimising header pressures to reduce throttling losses
- balancing steam loads on boilers and turbines using incremental cost to ensure optimum operation
- ensuring appropriate power purchases from the electricity company, varying loads with price changes.

The controllers are achieving high on-stream factors. Slight additional tuning to improve performance was

done based on the first three months of operation. The estimated benefits from this project are in excess of US\$1 million per year.

Possible extensions

A number of future issues may arise regarding this utility plant management system.

Adding process equipment

Steam balance will probably change as steam users change. New manufacturing units are being constructed and others are slated to close, as Mitsubishi adapts to changing world markets for its chemical products. Additional utility equipment such as a new turbine may be added, creating new handles for optimisation and possibly additional constraints. This project demonstrated that commissioning new variables within the controller can be done in less than three weeks, including all of the necessary steps: configuring and tuning base DCS controls, plant testing and model identification. This was typical of the quick re-tests done for the new variables in the various shutdown-mode controllers (M1-M6).

Power contract change

Another possible change is the power contract. The

present arrangement is based on a rate schedule with a simple maximum demand limit fixing the maximum amount of MWh. The utility management advanced control system could easily accommodate a contract change and adapt to real-time pricing (RTP) should the electricity market change in this way. Under RTP, the price changes frequently to reflect the constantly changing (real-time) costs for the electricity company to supply electricity. The real-time prices could be retrieved via modem from the electricity company; the linear program cost factors would automatically adjust as costs per hour rise and fall, and the controller will move the plant to new optimum operating conditions.

RTP contracts may include a total purchase limit, or other clauses and conditions. Typically, if a plant exceeds the contracted demand threshold usage, a new demand threshold is set and the plant pays for additional demand charges for 12 months, due to the demand ratchets in the contracted rate. Demand-limit tie line control regulates purchased electricity for the prescribed demand interval to ensure that the accumulative purchased power does not exceed the commitment. To accommodate this in the controller, the maximum demand limit can be adjusted at each controller cycle based on the remaining power in the demand interval (typically 15 minutes). As the import limit is 'pinched', the controller would increase on-site generation, for example by venting low-pressure steam. Thus, the instantaneous maximum power that can be purchased is reduced as the total purchase reaches the limit in the demand interval.

Real-time optimisation

The multivariable control system can push process variables to operating limits and minimise operating cost based on its embedded linear program. However, a linear control system with a linear program cannot fully optimise several degrees of freedom in plant operations requiring non-linear rigorous models such as turbine load allocation.

Power utility plants are good candidates for closed-loop, real-time optimisation, which can only be justified if process economics are a function of the operating point or the control system has redundant degrees of freedom. For example, turbine performance often has a point of peak efficiency and boiler costs are a function of boiler loads. In both cases, the importance of a controlled variable, which is based on marginal costs, may change because its cost relative to another controlled variable changes. Optimisation benefits are achieved by limiting each set point to its operating range of relative peak efficiency.

Real-time optimisation system objectives for a power plant are:

- optimise extraction flow rates to maximise turbine efficiencies and relieve valve constraints
- optimise extraction flow rates to relieve turbine maximum flow constraints

- optimise boiler loading to minimise steam generation costs
- optimise superheat temperature set point to trade-off improved turbine efficiency with reduced turbine capacity
- optimise turbine rates to maximise turbine efficiency.

AspenTech's real-time rigorous non-linear optimisation software, Aspen RT-Opt, uses an open-equation model formulation to solve all model interactions simultaneously. This allows back-end constraints to be fixed and feed rates to be calculated. The company's rapid solution optimisation technology has been successfully applied at another of Mitsubishi's power plants in Mizushima.³

Conclusions

In elapsed time, the project took two years from initial kick-off to completion, including the DCS upgrade, control room migration and InfoPlus-X database configuration, which were outside the scope of the advanced control project. The steady-state optimiser facilitates the control system configuration that includes all required functions of cogeneration utility management in a single application. The linear program naturally allows the controller to balance boiler, turbine and generator loads, determine required on-site power generation and minimise header pressures. Operator acceptance has been high, with the application markedly improving performance of the boilers and the overall management of the utility plant. Estimated benefits from this project are in excess of US\$1 million per year.

Acknowledgments

The authors thank and acknowledge the input of the engineers who participated in this project: John Ayala, David Birdseye, Homa Omrani and Mohamed Kamuss (AspenTech); Minoru Yoneda, Takashi Kokubu, Yoshiyuki Tsuji and Takeshi Kanamori (Mitsubishi).

References

- 1 CUTLER, C. R., and RAMAKER, B. L.: 'Dynamic matrix control-a computer control algorithm', Proceedings of American Control Conference, San Francisco, USA, 1980
- 2 EMOTO, G., OTA Y., MATSUO, H., OGAWA, M., RAVEN, D. B., PRESTON, R. F., and AYALA, J. S.: 'Integrated advanced control and closed-loop real-time optimization of an olefins plant', Proceedings of IFAC Symposium ADCHEM 94', Kyoto, Japan, 1994
- 3 FUJITA, K., EMOTO, G., TSUDA, A., and NAKAGAWA, S.: 'Real-time Optimization of a Power Plant in Petrochemical Complex', AspenTech's Advanced Control & Optimization World Users Group Meeting, Houston, USA, 1998
- 4 GOODHART, S.G., 'Advanced Process Control Using DMCplus', UKACC International Conference, Control '98, 1st-4th September 1998, Swansea, UK. IEE Conference Publication Number 455, pp. 439-444

© IEE: 2000

Sean Goodhart is with AspenTech Ltd., Global Solutions, Cambridge, UK, <http://www.AspenTech.com>. Jun Nishizawa, Kunihisa Yano and Hiroyuki Yada are with Mitsubishi Chemical Corporation, Yokkaichi, Japan.